

Operator Manual



IMPORTANT –Please make certain that persons who are to use this equipment thoroughly read and understand these instructions and any additional instructions provided prior to operation.

Record the model and serial numbers of your Generator below:

Model No. _____ Serial No. _____

Introduction	1	Section 6 — Maintenance	10
Section 1 — Safety Rules	1	6.1 Maintenance Schedule.....	10
Standards Index	1	6.2 General Recommendations	10
Section 2 — General Information.....	4	6.2.1 Generator Maintenance.....	10
2.1 Unpacking.....	4	6.2.2 To Clean the Generator	10
2.2 Assembly.....	4	6.2.3 Engine Maintenance	10
Section 3 —Features and Controls	5	6.2.4 Changing the Oil	11
Section 4 — Preparation		6.2.5 Replacing the Spark Plug	11
Before Operation.....	6	6.2.6 Spark Arrestor.....	11
4.1 Adding Engine Oil	6	6.3 Service Air Filter	11
4.2 Adding Fuel.....	6	6.4 Valve Clearance.....	12
4.3 Grounding the Generator	6	6.5 General.....	12
Section 5 — Operation.....	7	6.6 Other Storage Tips	12
5.1 Starting the Engine	7	Section 7 — Storage.....	12
5.2 Connecting Electrical Loads	9	Section 8 — Warranty Policy.....	13
5.3 Stopping the Engine	9		
5.4 Low Oil Level Shutdown System	9		
5.5 High Altitude	9		

INTRODUCTION

Thank you for purchasing products from Powertech, we appreciate your business. Our generator is a compact, high performance, air-cooled, engine driven generator designed to supply electrical power to operate electrical loads on job sites, or to run home appliances during outage; or provide power to remote locations where utility power is unavailable.

This manual contains of safety information to make you aware of hazards and risks associated with generator products and how to avoid them. It is important that you read and understand these instructions thoroughly before attempting to start or operate this equipment. Save this original instruction for future reference.

If any portion of this manual is not understood, contact the nearest authorized dealer for starting, operating and servicing procedures. We also strongly recommend you to instruct any other users who may operate the equipment in an emergency needed.

Every effort has been made to ensure that information in this manual is both accurate and current. However, Powertech Asia Pacific Inc. reserves the right to change, alter or otherwise improve the generator and this documentation at any time without prior notice.

SECTION 1 – SAFETY RULES



Read this manual carefully and become familiar with your generator. Know its applications, its limitations and any hazards involved.

Throughout this publication, and on tags and decals affixed to the generator, DANGER, WARNING, CAUTION and NOTICE blocks are used to alert personnel with special instructions about a particular operation that may be hazardous if performed incorrectly or carelessly. Observe them carefully. Their definitions are as follows:

DANGER indicates a hazard which, if not avoided, will result in death or serious injury.

WARNING indicates a hazard which, if not avoided, could result in death or serious injury.

CAUTION indicates a hazard which, if not avoided, could result in minor or moderate injury.

NOTICE covers some practices not related to personal injury.

Safety Symbols and Meanings

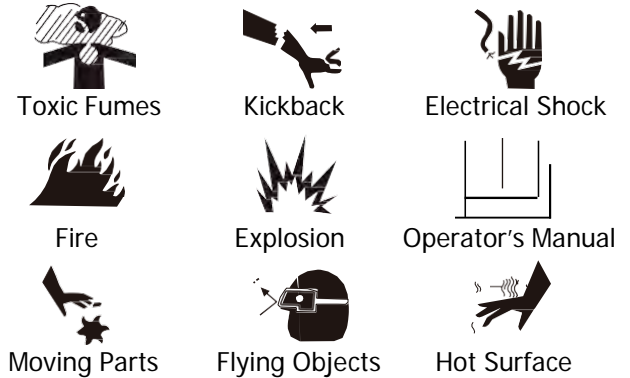

DANGER

Using a generator indoors **CAN KILL YOU IN MINUTES.**
Generator exhaust contains carbon monoxide. This is a poison you cannot see or smell.

NEVER use inside a home or garage, **EVEN IF** doors and windows are open.

Only use **OUTSIDE** and far away from windows, doors, and vents.

WARNING A running engine gives off carbon monoxide, an odorless, colorless, poison gas. Breathing carbon monoxide could result in death, serious injury, headache, fatigue, dizziness, vomiting, confusion, seizures, nausea or fainting.

- Operate this product **ONLY** outdoors.
- Install a battery-operated carbon monoxide alarm near the bedrooms.
- Keep exhaust gas away from entering a confined area through windows, doors, ventilation intakes, or other openings.
- **NEVER** operate this product inside any building, carport, porch, mobile equipment, marine applications, or enclosure, even if windows and doors are open.

 **WARNING** Starter cord kickback (rapid retraction) will pull hand and arm toward engine faster than you can let go which could cause broken bones,



fractures, bruises, or sprains resulting in serious injury.

- When starting engine, pull cord slowly until resistance is felt and then pull rapidly to avoid kickback.
- NEVER start or stop engine with electrical devices plugged in and turned on.

 **WARNING** Fuel and its vapors are extremely flammable and explosive which could cause burns, fire or explosion



resulting in death, serious injury and/or property damage.

WHEN ADDING OR DRAINING FUEL

- Turn generator engine OFF and let it cool at least 2 minutes before removing fuel cap. Loosen cap slowly to relieve pressure in tank.
- Fill or drain fuel tank outdoors.
- DO NOT overfill tank, Allow space for fuel expansion.
- If fuel spills, wait until it evaporates before starting engine.
- Keep fuel away from sparks, open flames, pilot light, heat, and other ignition sources.
- Check fuel lines, tank, cap and fittings frequently for cracks or leaks. Replace if necessary.
- DO NOT light a cigarette or smoke.

WHEN STARTING EQUIPMENT

- Ensure spark plug, muffler, fuel cap, and air cleaner are in place.
- DO NOT crank engine with spark plug removed.

WHEN OPERATING EQUIPMENT

- DO NOT operate this product inside any building, carport, porch, mobile equipment, marine applications, or enclosure.
- DO NOT tip engine or equipment at angle which cause fuel to spill.
- DO NOT stop engine by moving choke control to "OFF" position.

WHEN TRANSPORTING, OR REPAIRING EQUIPMENT

- Transport/move/repair with fuel tank EMPTY or with fuel valve OFF.
- DO NOT tip engine or equipment at angle which cause fuel to spill.
- Disconnect spark plug wire.

WHEN STORING FUEL OR EQUIPMENT WITH FUEL IN TANK

- Store away from furnaces, stoves, water heaters, clothes dryers, or other appliances that have light or other ignition source because they could ignite fuel vapors.

 **WARNING** Generator voltage could cause electrical shock or burn resulting in death or serious injury.



- Use approved transfer equipment to prevent back feed by isolating generator from electric utility workers.
- When using generator for backup power, notify utility company.
- Use a ground fault circuit interrupter in any damp or highly conductive area, such as metal decking or steel work.
- DO NOT touch bare wires or receptacles.
- DO NOT use generator with electrical cords which are worn, frayed, bare or otherwise damaged.
- DO NOT operate generator in the rain or wet weather.
- DO NOT handle generator or electrical cords while standing in water, while barefoot, or while hands or feet are wet.
- DO NOT allow unqualified persons or children to operate or service generator.

 **WARNING** Exhaust heat/gases could ignite combustibles, structures or damage fuel tank causing a fire, resulting in death, serious injury



- and/or property damage. Contact with muffler area could cause burns resulting in serious injury.
- DO NOT touch hot parts and AVOID hot exhaust gases.
 - Allow equipment to cool before touching.
 - Keep at least 5 feet (1.5m) of clearance on all sides of generator including overhead.

⚠ CAUTION Excessively high operating speeds could result in minor injury and/or generator damage.

Excessively low speeds impose a heavy load.

• DO NOT tamper with governor spring, links or other parts to increase engine speeds. Generator supplies correct rated frequency and voltage when running at governed speed.

⚠ WARNING Unintentional sparking could cause fire or electric shock resulting in death or serious injury.



WHEN ADJUSTING OR MAKING REPAIRS TO YOUR GENERATOR

• Disconnect the spark plug wire from the spark plug and place the wire where it cannot contact spark plug.

WHEN TESTING FOR ENGINE SPARK

• Use approved spark plug tester.
• DO NOT check for spark with spark removed.

⚠ WARNING Starter and other rotating parts could entangle hands, hair, clothing, or accessories resulting in serious injury.

• NEVER operate generator without protective housing or covers.
• DO NOT wear loose clothing, jewelry or anything that could be caught in the starter or other rotating parts.
• Tie up long hair and remove jewelry.
• DO NOT modify generator in any way.

⚠ NOTICE Exceeding generators wattage/ amperage capacity could damage generator and/or electrical devices connected to it.

• DO NOT exceed the generator's wattage/ amperage capacity. See Don't Overload Generator in the Operation section.
• Start generator and let engine stabilize before connecting electrical loads.
• Turn electrical loads OFF and disconnect from generator before stopping generator.

⚠ NOTICE Improper treatment of generator could damage it and shorten its life.

• Use generator only for intended uses.
• If you have questions about intended use, ask dealer or contact local service center.
• Operate generator only on level surfaces.
• DO NOT expose generator to excessive moisture, dust, dirt, or corrosive vapor.
• DO NOT insert any object through cooling slots.
• If connected devices overheat
-or electrical output is lost.
-or equipment sparks, smokes, or emits flames.
-or unit vibrates excessively.
To turn them off and disconnect them from generator

SECTION 2 — GENERAL INFORMATION

2.1 UNPACKING

- Set the carton on a rigid, flat surface.
- Remove everything from carton except generator.
- Open carton completely by cutting each corner from top to bottom.
- Leave generator on carton to install wheel kit.

2.1.1 PACKING CONTENTS

- 1-Owner's Manual
- 2-Wheels
- 1-Handle Assembly
- 2-Wheel Axle
- 1-Hardware Bag
(including 1-Spark Plug Socket; 1-Extension Housing)

The above contents in this manual are for reference only and do not represent for any specific model.

2.2 ASSEMBLY

The generator requires some assembly prior to using it.

2.2.1 ASSEMBLING THE ACCESSORY KIT

The wheels are designed to greatly improve the portability of the generator.

⚠ NOTE The wheels are Not intended for over-the-road use.

1. Refer to Figures to install wheels as shown.

- Slide the axle through the frame brackets.
- Slide on the hub, wheel and flat washer, then insert the cotter pin through the wheel axle hole.
- Bend the cotter pin tabs outward to lock the pin in place.

2. The wheel bumpers as shown.

- Insert an M6 bolt through the rubber bumper and insert an M8 bolt through the bottom of the bumper bracket. Secure the bolt with an M8 flange nut.
- Install an M8 bolt through the generator frame and through top of the bumper bracket. Secure the bolt with an M8 flange nut.

Refer to following Figure to install the handle assembly as shown.

- Insert the handle bracket onto the generator frame and secure with two M8 bolts and two M8 flange nuts.

Align the handle assembly holes with the handle bracket holes and secure with one M8 bolt and one M8 flange nut.

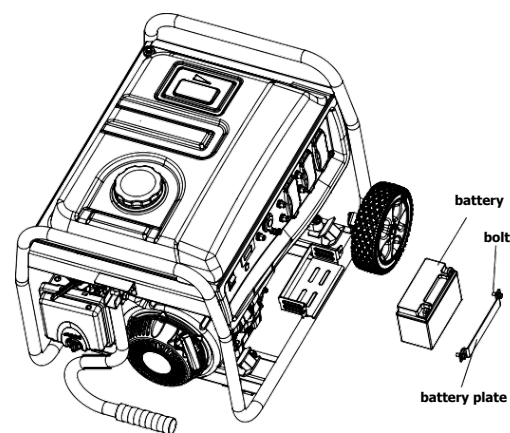
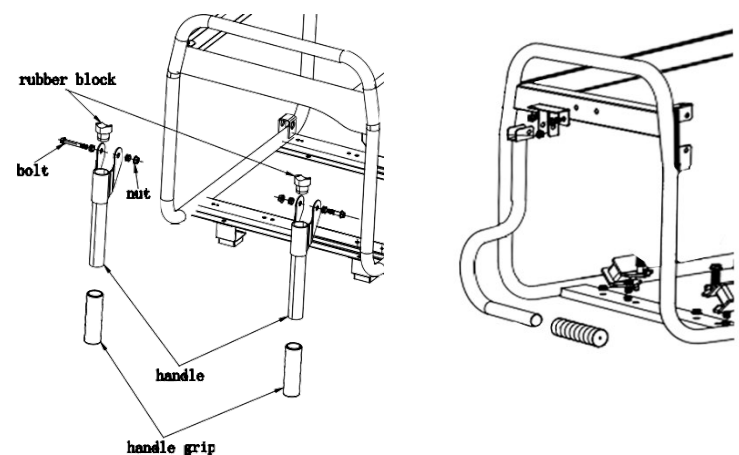
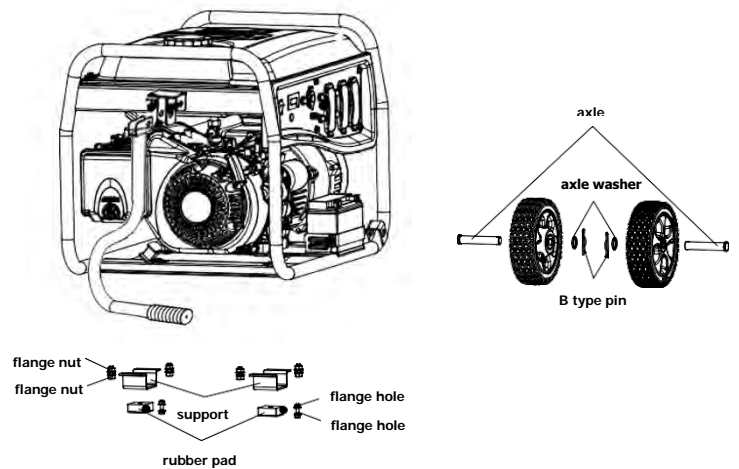

3.

SECTION 3 — FEATURES AND CONTROLS



Read this Operator's Manual and safety rules before operating your generator. Compare the illustrations with your generator, to familiarize yourself with the locations of various controls and adjustments. Save this manual for future reference.

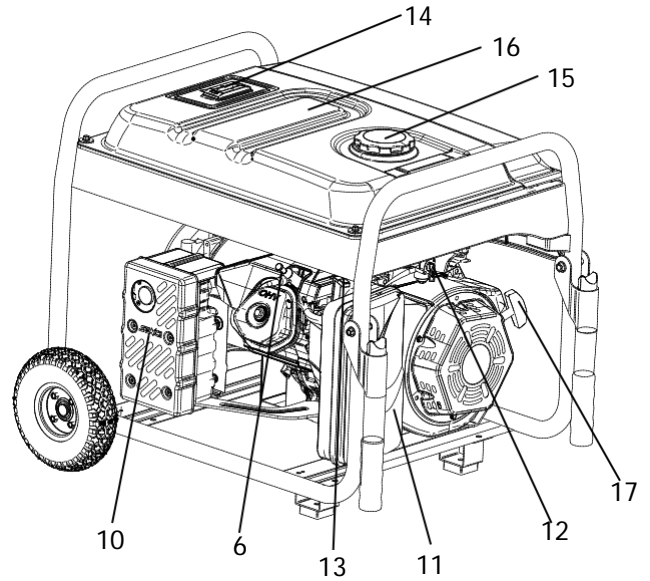
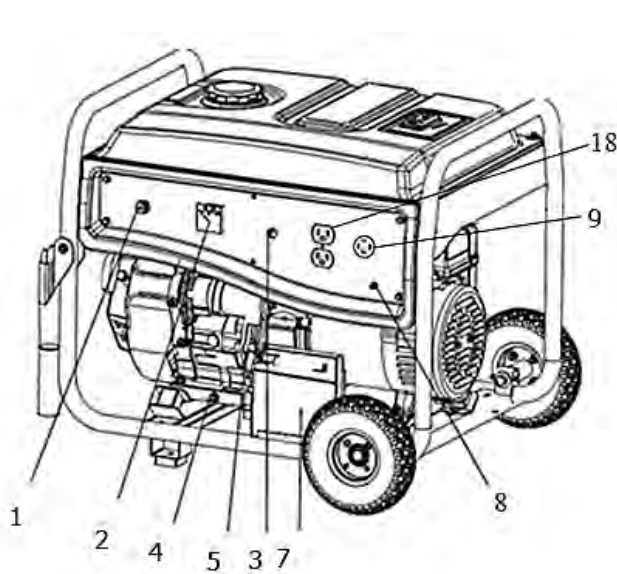

Special for 5 kw to 10 kw

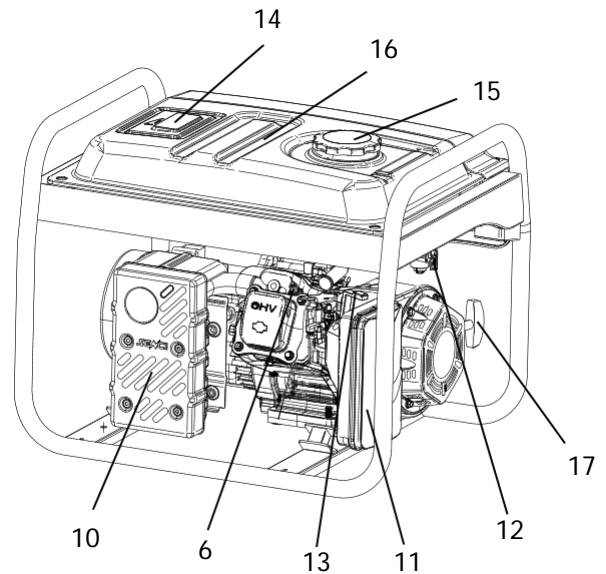
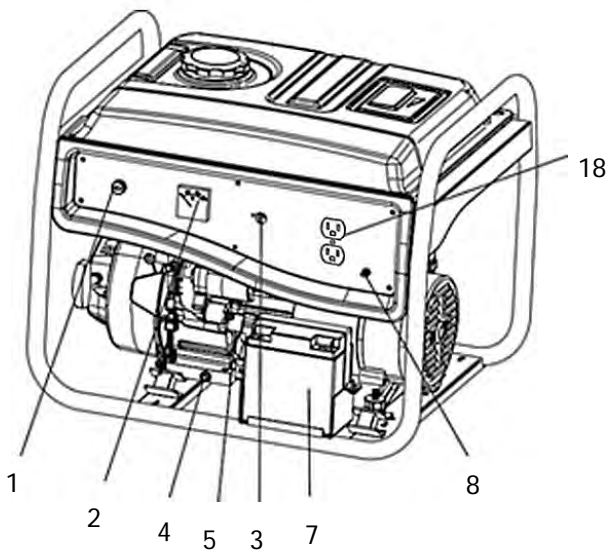

Special for 1 kw to 4 kw

1	ENGINE SWITCH	10	MUFFLER
2	VOLTMETER	11	AIR CLEANER
3	AC CIRCUIT BREAKER	12	FUEL VALVE
4	OIL DRAIN PLUG	13	CHOKE LEVER
5	OIL FILL CAP/DIPSTICK	14	FUEL GAUGE
6	SPARK PLUG	15	FUEL TANK CAP
7	BATTERY	16	FUEL TANK
8	GROUND TERMINAL	17	RECOIL STARTER
9	115/230v RECEPTACLE	18	DUPLEX RECEPTACLE

⚠ NOTICE

Pictures and drawings used in this manual are for reference only and do not represent any specific model.

SECTION 4 — PREPARATION BEFORE OPERATION

4.1 ADDING ENGINE OIL

Please add properly oil before starting the generator. Use nonspecial additives. Select the oil's Viscosity grade according to the expected operating temperature (also see chart).

Above 40 F, use SAE 30

Below 40 F and down to 10 F, use 10W-30

Below, 10 F use synthetic 5W-30

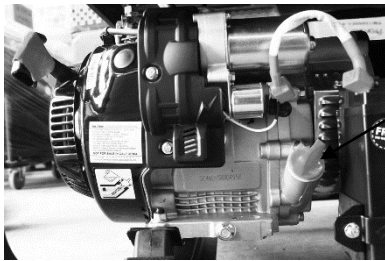
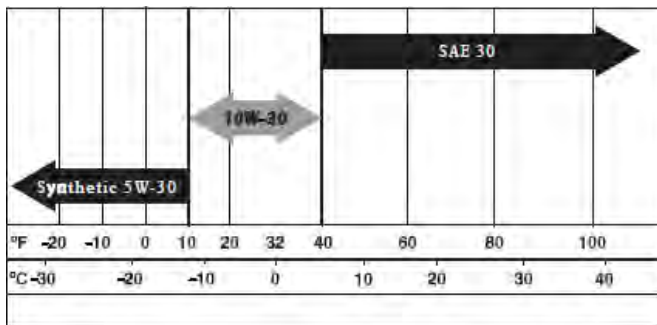

⚠ NOTICE Improper treatment of generator could damage it and shorten its life. DO NOT attempt crank or start the engine before it has been properly serviced with the recommended oil. This could result in an engine failure.

- Place generator on a flat, level surface.
- Clean area around oil fill and remove oil fill cap / dipstick. Wipe dipstick clean.
- Slowly fill engine with oil through the oil fill opening until it reaches the full mark on the dipstick. Stop filling occasionally to check oil level. Be careful do not over fill.
- Install oil fill cap and finger tighten securely
- Check engine oil level before starting each time thereafter.

4.2 ADDING FUEL

⚠ DANGER Never fill tank indoors. Never fill fuel tank when engine is running or hot. Turn generator engine

OFF and allow engine to cool entirely before filling fuel tank. Avoid spilling gasoline on HOT engine. Keep fuel away from sparks, open flames, pilot lights, heat, and other ignition sources. DO NOT light a cigarette or smoke when filling the fuel tank. Fuel is highly FLAMMABLE and its vapors are EXPLOSIVE.

- Use regular UNLEADED gasoline with the generator engine. Do not use any fuel with more than 10% added ethanol, and never use E85 fuel.
- Do not mix oil with gasoline.
- Install fuel cap and wipe up any spilled gasoline.

⚠ CAUTION Do not overfill the fuel tank. Allow space for fuel expansion. IF the fuel tank is overfilled, fuel can overflow onto a HOT engine and cause FIRE or EXPLOSION. If fuel spills, wait until it evaporates before starting engine. Check fuel lines, tank, cap and fittings frequently for cracks or leaks. Replace if necessary.

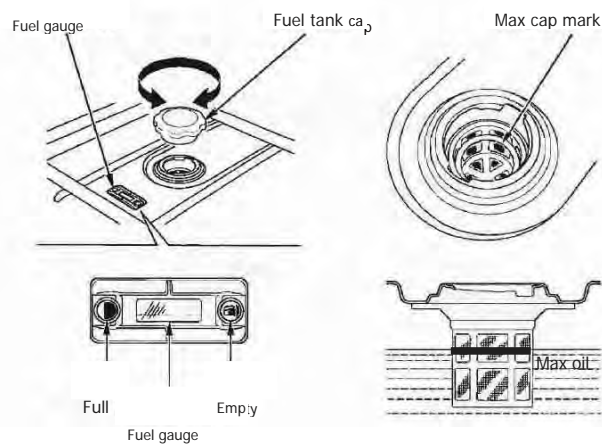

IMPORTANT: It is important to prevent gum deposits from forming in fuel system parts such as the carburetor, fuel hose or tank during storage. Alcohol-blended fuels (called gasohol), ethanol or methanol) can attract moisture, which leads to separation and formation of acids during storage. Acidic gas can damage the fuel system. The fuel should be emptied before storage of 30 days or longer. See the "Storage" section. Never use engine or carburetor cleaner products in the fuel tank as permanent damage may occur.

4.3 GROUNDING THE GENERATOR

The national Electrical Code requires that the frame and external electrically conductive part of this generator be properly connected to an approved earth ground.

SECTION 5 — OPERATION

5.1 STARTING THE ENGINE

⚠ WARNING Never start or stop engine with

electrical devices plugged into the receptacles AND devices turned on.

Unplug all electrical loads from the unit's receptacles before starting the engine. Make sure the unit is in a level position.

WATTAGE REFERENCE GUIDE

Wattage Reference Guide		
Tool or Appliance	Running (Rated) Watts	Additional Starting (Surge) Watts
Essentials		
Light Bulb - 75 watt	75	—
Furnace Fan Blower - 1/2 HP	800	2350
Sump Pump - 1/3 HP	800	1300
Refrigerator/Freezer	700	2200
Water Well Pump - 1/2 HP	1000	2100
Heating/Cooling		
Window AC - 10,000 BTU	1200	3600
Humidifier - 13 Gal	175	—
Central AC - 24,000 BTU	3800	11400
Kitchen		
Microwave Oven - 1000 Watt	1000	—
Coffee Maker	1000	—
Electric Stove - 8"	2100	—
Toaster	850	—
Family Room		
DVD/CD Player	100	—
VCR	100	—
Stereo Receiver	450	—
Color Television - 27 in	500	—
Personal Computer w/17 in monitor	800	—
Other		
Security System	500	—
AM/FM Clock Radio	100	—
Garage Door Opener - 1/2 HP	875	2350
Electric Water Heater	4700	11700
DIY/Job Site		
Quartz Halogen Work Light	1000	—
Airless Sprayer - 1/3 HP	600	1200
Reciprocating Saw	960	—
Electric Drill - 1/2 HP, 5.	600	900
Circular Saw - 7-1/4 in	1400	2300
Miter Saw - 10 in	1800	1800
Table Planer - 6 in	1800	1800
Table Saw/Radial Arm Saw -	2000	2000
Air Compressor - 1 HP	1600	4500

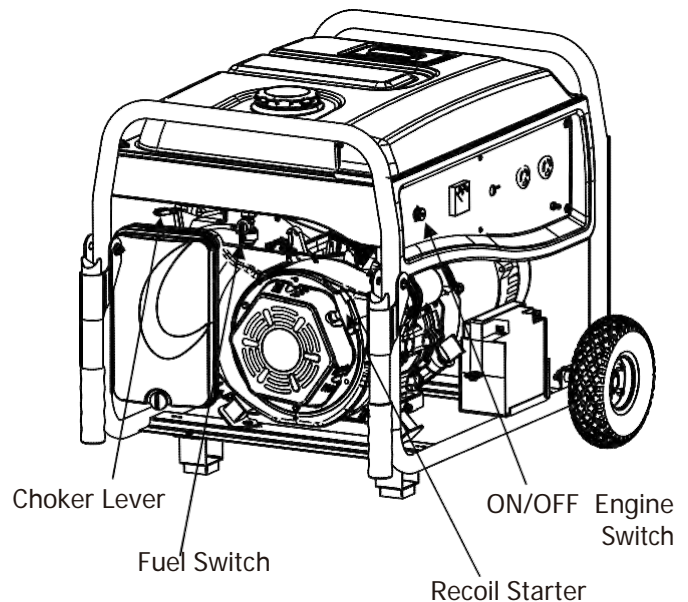

Turn the Engine Switch to "ON" position.

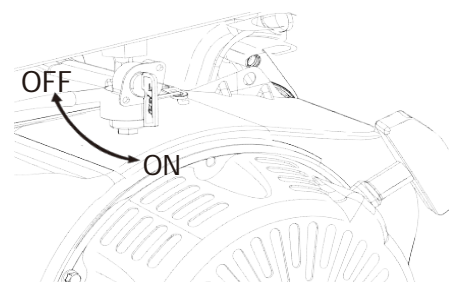
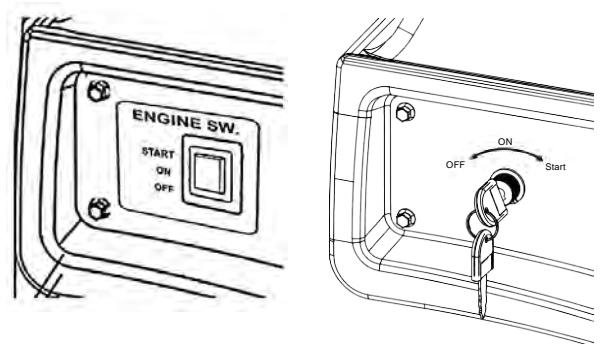

Turn Fuel Switch to ON position

Move engine choke lever to the OFF position

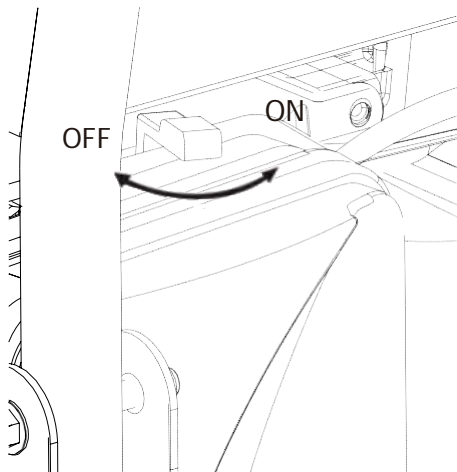

For Recoil start, firmly grasp the recoil handle and pull slowly until increased resistance is felt. Pull rapidly up and away.

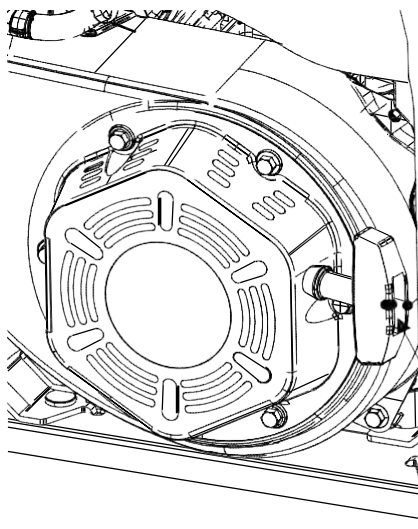

Recoil Starter

For electric start, turn and hold key in start switch to "start" position until generator starts. To prolong the life of starter components, DO NOT hold key in "start" position for more than 15 seconds, and pause for at least 1 minute between starting attempts.

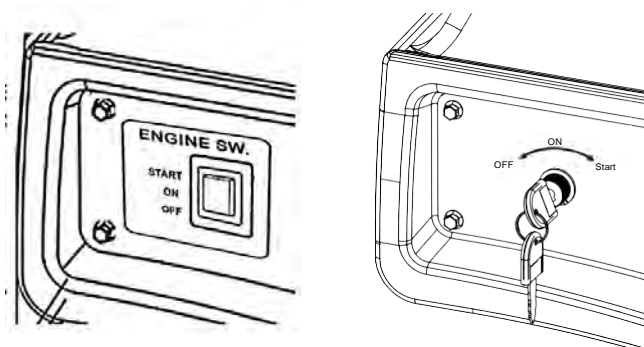

When engine starts, move choke lever to 1/2-CHOKE position until engine runs smoothly and then fully into ON position. If engine falters, move choke back out to 1/2-CHOKE position until engine runs smoothly and then fully into ON position.

⚠ NOTICE If battery is discharged, use manual starting instructions.

⚠ NOTICE If engine fires, but does not continue to run, move choke lever to the OFF position and repeat starting instructions.

⚠ WARNING Starter cord kickback (rapid retraction) will pull hand and arm toward engine faster than you can let go which could cause broken bones, fractures, bruises, or sprains resulting in serious injury.

When starting engine, pull cord slowly until resistance is felt and then pull rapidly to avoid kickback.

Never start or stop engine with electrical devices plugged in and turned on.

⚠ NOTICE If engine fails to start 3 pulls, or if unit shut down during operation, make sure unit is on a level surface and check for proper oil level in crankcase. This unit may be equipped with a low oil protection device. If so, oil must be checked at proper level for engine to start and run.

⚠ WARNING Exhaust heat/ gases could ignite combustible, structures or damage fuel tank causing a fire, resulting in death,

serious injury and/or property damage. Contact with muffler area could cause burn resulting in serious injury.

DO NOT touch hot part and AVOID hot exhaust gases.

Allow equipment to cool before touching.

Keep at least 5 feet (152 cm) of clearance on all sides of generator including overhead.

Contact the original equipment manufacturer, retailer, or dealer to obtain a spark arrester designed for the exhaust system installed on this engine.

Replacement parts must be the same and installed in the same position as the original parts.

IMPORTANT Do not overload the generator. Also, do not overload individual panel receptacles. These outlets are protected against overload with push-to-reset-type circuit breakers. If amperage rating of any circuit breaker is exceeded, that breaker opens and electrical output to that receptacle is lost.

5.2 CONNECTING ELECTRICAL LOADS

- Let engine runs stable and warm up for a few minutes after starting.
- Plug in and turn on the electrical loads.
- Add up the rated watts (or amps) of all loads to be connected at one time. This total should not be greater than (a) the rated wattage/amperage capacity of the generator or (b) circuit breaker rating of the receptacle supplying the power.

⚠ **NOTICE** Start generator and let engine stabilize before connecting electrical loads. Connect electrical loads in OFF position then turn ON for operation. Turn electrical loads OFF and disconnect from generator before stopping generator.

⚠ **NOTICE** Exceeding generators wattage/ amperage capacity could damage generator and/or electrical devices connected to it. DO NOT exceed the generator's wattage/amperage capacity.

- Overloading a generator in excess of it rated wattage capacity can result in damage to the damage to the generator and to connected electrical devices. Observe the following to prevent overloading the unit:
 - Add up the total wattage of all electrical devices to be connected at one time. This total should NOT be greater than the generator's wattage capacity.

The rated wattage of lights can be taken from light bulbs. The rated wattage of tools, appliances and motors can usually be found on a data label or decal affixed to be the device. If the appliance, tool or motor does not give wattage, multiply volts times ampere rating to determine watts (volts× amps = watts).

Some electric motors, such as induction types, require about three times more watts of power for starting than for running. This surge of power lasts only a few seconds when starting such motors. Make sure to allow for high starting wattage when selecting electrical devices to connect to the generator:

- Figure the watts needed to start the largest motor.
- Add to that figure the running watts of all other connected loads.

The wattage reference guide is provided to assist in determining how many items the generator can operate at one time.

5.3 STOPPING THE ENGINE

Shut off all loads then unplug the electrical loads from generator panel receptacles. Never start or stop the engine with electrical devices plugged in and turned on.

Let engine run at no-load for several minutes to stabilize the internal temperatures of engine and generator.

Move ON/OFF switch to OFF position. Close fuel valve.

5.4 LOW OIL LEVEL SHUTDOWN SYSTEM

The engine is equipped with a low oil level sensor that shuts down the engine automatically when the oil level drops below a specified level. If the engine shuts down by itself and the fuel tank has enough gasoline, check engine oil level.

5.5 HIGH ALTITUDE

At altitudes over 5,000 feet (1524 meters), a minimum 85 octane / 85 (89 RON) gasoline is acceptable. To remain emissions compliant, high altitude adjustment is required. Operation without this adjustment will cause decreased performance, increased fuel consumption, and increased emissions. See an authorized dealer for high altitude adjustment information. Operation of the engine at altitudes below 2,500 feet (762 meters) with the high-altitude kit is not recommended.

SECTION 6 — MAINTENANCE

6.1 MAINTENANCE SCHEDULE

Follow the calendar intervals shown below. More frequent service is required when operating in adverse conditions.

First 5 Hours
• Change engine oil
Every 8 Hours or Daily
• Clean debris
• Check engine oil level
Every 25 Hours or Yearly
• Clean engine air filter
Every 50 Hours or Yearly
• Change engine oil
Yearly
• Replace engine air filter
• Service fuel valve
• Service spark plug
• Inspect muffler and spark arrester
• Clean cooling system

6.2 GENERAL RECOMMENDATIONS

The warranty of the generator does not cover items that have been subjected to operator abuse or negligence. To receive full value from the warranty, the operator must maintain the generator as instructed in this manual.

Some adjustments will need to be made periodically to properly maintain the generator.

All adjustments in the Maintenance section of this manual should be made at least once each season. Follow the requirements in the "Maintenance Schedule".

⚠ NOTE Once a year replace the spark plug and replace the air filter. A new spark plug and clean air filter assure proper fuel-air mixture and help the engine run better and last longer.

6.2.1 GENERATOR MAINTENANCE

Generator maintenance consists of keeping the unit clean and dry. Operate and store the unit in a clean dry environment where it will not be exposed to excessive dust, dirt, moisture or any corrosive vapors. Cooling air slots in the generator must not become clogged with snow, leaves, or any other foreign material.

Check the cleanliness of the generator frequently and clean when dust, dirt, oil, moisture or other foreign substances are visible on its exterior surface.

⚠ CAUTION Never insert any object or tool though the air cooling slots, even if the engine is not running.

⚠ NOTE DO NOT use a garden hose to clean generator. Water can enter the engine fuel system and cause problems. In addition, if water enters the generator though cooling air slots, some water will be retained in voids and crevices of the rotor and stator winding insulation. Water and dirt buildup on the generator internal windings will eventually decrease the insulation resistance of these windings.

6.2.2 TO CLEAN THE GENERATOR

- Use a damp cloth to wipe exterior surfaces clean.
- A soft, bristle brush may be used to loosen caked on dirt, oil etc.
- A vacuum cleaner may be used to pick up loose dirt and debris.
- Low pressure air (not to exceed 25 psi) may be used to blow away dirt. Inspect cooling air slots and openings on the generator. These openings must be kept clean and unobstructed.

6.2.3 ENGINE MAINTENANCE

⚠ DANGER When working on the generator, always disconnect spark plug wire from spark plug and keep wire away from spark plug.

6.2.4 CHANGING THE OIL

Change the oil after the first eight hours of operation, then every 50 hours thereafter. If running this unit under dirty or dusty conditions, or in extremely hot weather, to change the oil more often.

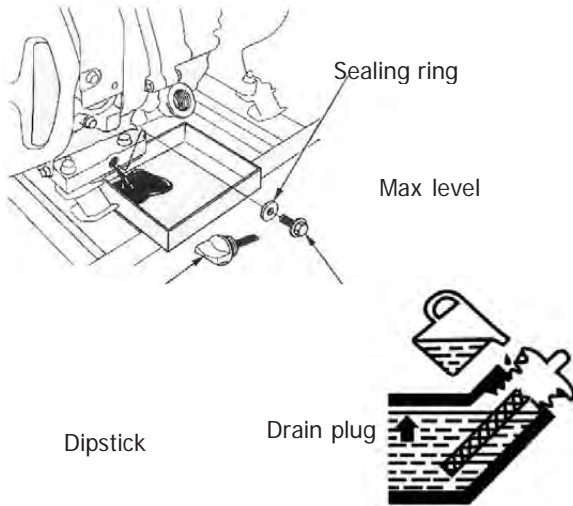

⚠ CAUTION Hot oil may cause burns. Allow engine to cool before draining oil. Avoid prolonged or repeated skin exposure with used oil. Thoroughly wash exposed areas with soap.

Use the following instructions to change the oil while the engine is still warm:

- Clean area around oil drain plug.
- Remove oil drain plug from engine and oil fill plug to drain oil completely into a suitable container.
- When oil has completely drained, install oil drain plug and tighten securely.
- Fill engine with recommended oil. (See "Before Starting the Generator" for oil recommendations).
- Wipe up any spilled oil.
- Dispose of used oil at a proper collection center.

6.2.5 REPLACING THE SPARK PLUG

Use spark plug F6TC, BPR4ES or Champion RN14YC. Replace the plug once each year. This will help the engine start easier and run better.

- Stop the engine and pull the spark plug wire off of the spark plug.
- Clean the area around the spark plug and remove it from the cylinder head.
- Set the spark plug's gap to 0.70-0.80 mm (0.028-0.031 in.). Install the correctly gapped spark plug into the cylinder head and torque to 15 ft/lbs.

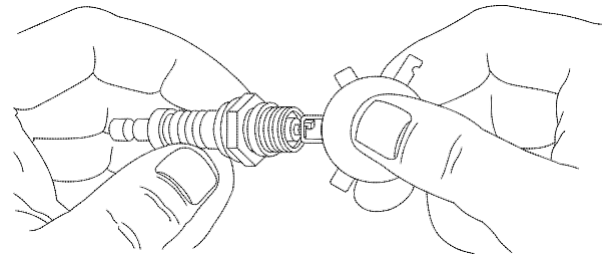

6.2.6 SPARK ARRESTOR

- Shut off generator and allow the engine and muffler to cool down completely before servicing spark arrestor (located on the back of the muffler).
- Remove the clamp and spark arrestor screen.
- Clean the spark arrestor screen with a small wire brush.
- Replace the spark arrestor if it is damaged.
- Installation of the spark arrestor screen is the reverse of the removal.

6.3 SERVICE AIR FILTER

The engine will not run properly and may be damaged if using a dirty air filter. Replace the air filter once a year. Clean or replace more often if operating under dusty conditions.

- Remove air filter cover.
- Wash in soapy water. Squeeze filter dry in clean cloth (DO NOT TWIST).
- May drop a bit of engine-oil to avoid ice blocked during winter season.
- Clean air filter cover before re-installing it.

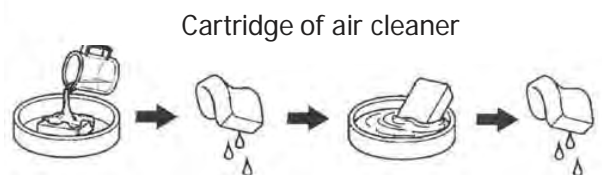
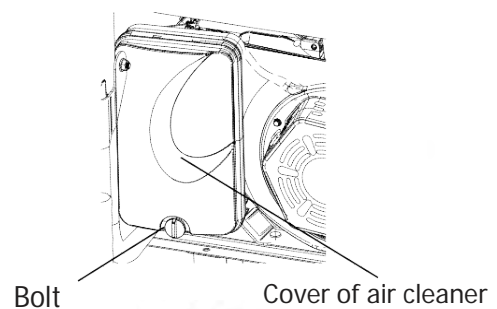

6.4 VALVE CLEARANCE

After the first 50 hours of operation, check the valve clearance in the engine and adjust if necessary.

Important: If feeling uncomfortable about doing this procedure or the proper tools are not available, please take the generator to the nearest service center to have the valve clearance adjusted. This is a very important step to ensure longest life for the engine.

6.5 GENERAL

The generator should be started at least once every seven days and be allowed to run at least 30 minutes. If this cannot be done and the unit must be stored for more than 30 days, use the following information as a guide to prepare it for storage.

⚠ DANGER NEVER store engine with fuel in tank indoors or in enclosed, poorly ventilated areas where fumes may reach an open flame, spark or pilot light as on a furnace, water heater, clothes dryer or other gas appliance.

⚠ CAUTION Avoid spray from spark plug holes when cranking engine.

⚠ DANGER Drain fuel into approved container outdoors, away from open flame. Be sure engine is cool. Do not smoke.

6.6 OTHER STORAGE TIPS

- Do not store gasoline from one season to another.
- Replace the gasoline can if it starts to rust. Rust and/or dirt in the gasoline will cause problems with the carburetor and fuel system.
- If possible, store the unit indoors and cover it to give protection from dust and dirt. **BE SURE TO EMPTY THE FUEL TANK.**
- If it is not practical to empty the fuel tank and the unit is to be stored for some time, use a commercially available fuel stabilizer added to the gasoline to increase the life of the gasoline.
- Cover the unit with a suitable protective cover that does not retain moisture.

⚠ DANGER NEVER cover the generator while engine and exhaust area are warm.

SECTION 7 — STORAGE

It is important to avoid gum deposits from forming in essential fuel system parts such as the carburetor, fuel hose or tank during storage. Also, experience indicates that alcohol-blended fuels (called gasohol, ethanol or methanol) can attract moisture, which leads to separation and formation of acids storage. Acidic gas can damage the fuel system of an engine while in storage.

To avoid engine problems, the fuel system should be emptied before storage of 30 days or longer, as follows:

- Remove all gasoline from the fuel tank.
- Start and run engine until engine stops from lack of fuel.
- While engine is still warm, drain oil from crankcase. Refill with recommended grade.
- Remove spark plugs and pour about 1/2 ounce (15 ml) of engine oil the cylinders. Cover spark plug hole with rag. Pull the recoil starter a couple times to lubricate the piston rings and cylinder bore.

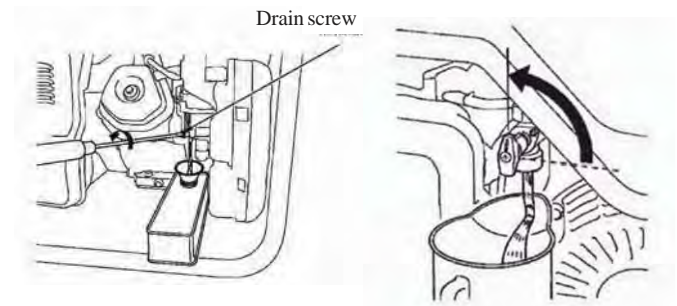

- Install and tighten spark plugs. Do not connect spark plug wires.
- Clean the generator outer surfaces. Check that cooling air slots and openings on generator are open and unobstructed.
- Store the unit in clean, dry place.
- Do not store gasoline from one season to another.
- Replace the gasoline can if it starts to rust. Rust and/or dirt in the gasoline will cause problems with the carburetor and fuel system.
- If possible, store the unit indoors and cover it to give protection from dust and dirt. **BE SURE TO EMPTY THE FUEL TANK.**
- If it is not practical to empty the fuel tank and the unit is to be stored for some time, use a commercially available fuel stabilizer added to the gasoline to increase the life of the gasoline.
- Cover the unit with a suitable protective cover that does not retain moisture.

SERVICE INFORMATION

HOW TO ORDER REPLACEMENT PARTS

Even quality-built equipment such as the generator you have purchased will need occasional replacement parts to maintain its good condition over the years.

To order replacement parts and consumable parts, please contact Promate Service (details below) and be ready with the following information:

1. Model No., Serial No. and all specifications that are shown on the Model No./Serial No. plate.
2. Part number or numbers as shown in the Parts List section.
3. A brief description of the trouble with the generator.

LIMITED WARRANTY

Warranty Coverage: Powertech Asia Pacific Inc., (the Company) warrants to the original retail customer that it will repair or replace, free of charge, any parts found by the Company or its authorized service representative to be defective in material or workmanship. This warranty covers the cost of replacement parts and labor for defects in material or workmanship.

Not Covered:

- Shipping/Handling charges for sending the product to the Company or its authorized service representative for warranty service. Shipping/Handling repaired or replaced products back to the customer; these charges must be borne by the customer.
 - If a separate operator's manual and engine warranty from the engine manufacturer is included with this product, only that warranty will apply to the engine.
 - Damage caused by abuse, accident, the effects of corrosion, erosion and normal wear and tear.
-
- Warranty is void if the customer fails to install, maintain and operate the product in

accordance with the instructions and recommendations of the Company set forth in the owner's manual, or if the product is used as rental equipment.

- The Company will not pay for repairs or adjustments to the product, or for any costs of labor performed without the Company's prior authorization.
- Consumable parts such as battery, spark plugs, and air cleaner.

Warranty Period: One (1) year from the date of purchase on products used solely for consumer applications; if a product is used for business or commercial applications, the warranty period will be limited to ninety (90) days from the date of purchase. For warranty service, the customer must provide dated proof of purchase and must notify the Company within the warranty period.

EXCLUSIONS AND LIMITATIONS: THE COMPANY MAKES NO OTHER WARRANTY OF ANY KIND, EXPRESS OR IMPLIED. IMPLIED WARRANTIES, INCLUDING WARRANTIES OF MERCHANTABILITY AND OF FITNESS FOR A PARTICULAR PURPOSE, ARE HEREBY DISCLAIMED. THE WARRANTY SERVICE DESCRIBED ABOVE IS THE EXCLUSIVE REMEDY UNDER THIS WARRANTY; LIABILITY FOR INCIDENTAL AND CONSEQUENTIAL DAMAGES IS EXCLUDED TO THE EXTENT PERMITTED BY LAW.

This warranty gives you specific legal rights, and you may also have other rights which vary from state to state. Some states do not allow a disclaimer of implied warranties or the exclusion or limitation of incidental and consequential damages, so the above disclaimers and exclusions may not apply to you.



CONTACT THE POWERTECH Asia Pacific Inc.,
PRODUCT SERVICE DEPARTMENT AT (+632) 984 2620 | 09228741679
service@powertechasiapacific.com
www.facebook.com/PromateServicePH/

(MAIN) #420 Diamond Warehouse Compound, F Legaspi St., Maybunga Pasig City 1607
(DAVAO) Space 10 & 11 Jin-Long Complex R. Castillo St., Agdao District, Davao City 8000



